

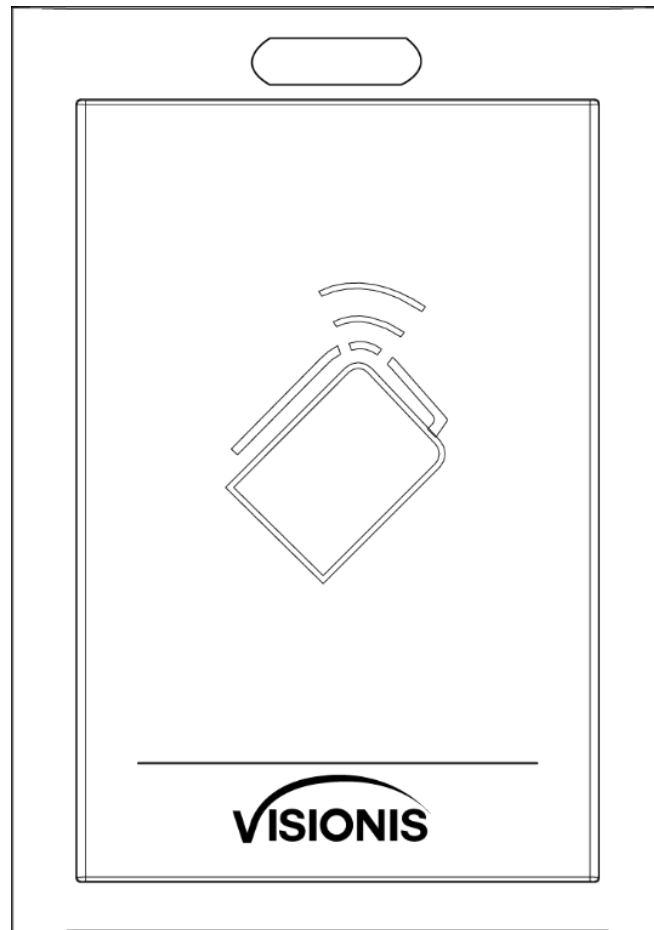

**Access Control Black with Clear
Border Card Reader Only Compatible
with Wiegand 26 and 34 Bit**



**VIS-3102
Installation Manual**

User Manual

COPYRIGHT ©2015 Visionis Technology.

ALL RIGHTS RESERVED.

Any and all information, including, among others, wordings, pictures, graphs are the properties of Visionis Technology or its subsidiaries (hereinafter referred to be "Visionis"). This user manual (hereinafter referred to be "the Manual") cannot be reproduced, changed, translated, or distributed, partially or wholly, by any means, without the prior written permission of Visionis. Unless otherwise stipulated, Visionis does not make any warranties, guarantees or representations, express or implied, regarding to the Manual.

About this Manual

The Manual includes instructions for using and managing the product. Pictures, charts, images and all other information hereinafter are for description and explanation only. The information contained in the Manual is subject to change, without notice, due to firmware updates or other reasons. Please find the latest version in the company website (<http://www.visionistech.com>).

Please use this user manual under the guidance of professionals.

Trademarks Acknowledgement

and other Visionis' trademarks and logos are the properties of Visionis in various jurisdictions. Other trademarks and logos mentioned below are the properties of their respective owners.

Legal Disclaimer

TO THE MAXIMUM EXTENT PERMITTED BY APPLICABLE LAW, THE PRODUCT DESCRIBED, WITH ITS HARDWARE, SOFTWARE AND FIRMWARE, IS PROVIDED "AS IS", WITH ALL FAULTS AND ERRORS, AND VISIONIS MAKES NO WARRANTIES, EXPRESS OR IMPLIED, INCLUDING WITHOUT LIMITATION, MERCHANTABILITY, SATISFACTORY QUALITY, FITNESS FOR A PARTICULAR PURPOSE, AND NON-INFRINGEMENT OF THIRD PARTY. IN NO EVENT WILL VISIONIS, ITS DIRECTORS, OFFICERS, EMPLOYEES, OR AGENTS BE LIABLE TO YOU FOR ANY SPECIAL, CONSEQUENTIAL, INCIDENTAL, OR INDIRECT DAMAGES, INCLUDING, AMONG OTHERS, DAMAGES FOR LOSS OF BUSINESS PROFITS, BUSINESS INTERRUPTION, OR LOSS OF DATA OR DOCUMENTATION, IN CONNECTION WITH THE USE OF THIS PRODUCT, EVEN IF VISIONIS HAS BEEN ADVISED OF THE POSSIBILITY OF SUCH DAMAGES.

REGARDING TO THE PRODUCT WITH INTERNET ACCESS, THE USE OF PRODUCT SHALL BE WHOLLY AT YOUR OWN RISKS. VISIONIS SHALL NOT TAKE ANY RESPONSIBILITIES FOR ABNORMAL OPERATION, PRIVACY LEAKAGE OR OTHER DAMAGES RESULTING FROM CYBER ATTACK, HACKER ATTACK, VIRUS INSPECTION, OR OTHER INTERNET SECURITY RISKS; HOWEVER, VISIONIS WILL PROVIDE TIMELY TECHNICAL SUPPORT IF REQUIRED.

SURVEILLANCE LAWS VARY BY JURISDICTION. PLEASE CHECK ALL RELEVANT LAWS IN YOUR JURISDICTION BEFORE USING THIS PRODUCT IN ORDER TO ENSURE THAT YOUR USE CONFORMS THE APPLICABLE LAW. VISIONIS SHALL NOT BE LIABLE IN THE EVENT THAT THIS PRODUCT IS USED WITH ILLEGITIMATE PURPOSES.

IN THE EVENT OF ANY CONFLICTS BETWEEN THIS MANUAL AND THE APPLICABLE LAW, THE LATER PREVAILS.

Regulatory Information

FCC Information

FCC compliance: This equipment has been tested and found to comply with the limits for a digital device, pursuant to part 15 of the FCC Rules. These limits are designed to provide reasonable protection against harmful interference when the equipment is operated in a commercial environment. This equipment generates, uses, and can radiate radio frequency energy and, if not installed and used in accordance with the instruction manual, may cause harmful interference to radio communications. Operation of this equipment in a residential area is likely to cause harmful interference in which case the user will be required to correct the interference at his own expense.

FCC Conditions

This device complies with part 15 of the FCC Rules. Operation is subject to the following two conditions:

1. This device may not cause harmful interference.

2. This device must accept any interference received, including interference that may cause undesired operation.

EU Conformity Statement



This product and -if applicable -the supplied accessories too are marked with "CE" and comply therefore with the applicable harmonized European standards listed under the EMC Directive 2004/108/EC, the RoHS Directive 2011/65/EU.



2012/19/EU (WEEE directive): Products marked with this symbol cannot be disposed of as unsorted municipal waste in the European Union. For proper recycling, return this product to your local supplier upon the purchase of equivalent new equipment, or dispose of it at designated collection points. For more information see: www.recyclethis.info.



2006/66/EC (battery directive): This product contains a battery that cannot be disposed of as unsorted municipal waste in the European Union. See the product documentation for specific battery information. The battery is marked with this symbol, which may include lettering to indicate cadmium (Cd), lead (Pb), or mercury (Hg). For proper recycling, return the battery to your supplier or to a designated collection point. For more information see: www.recyclethis.info.

Industry Canada ICES-003 Compliance

This device meets the CAN ICES-3 (A)/NMB-3(A) standards requirements.

Preventive and Cautionary Tips

Before connecting and operating your device, please be advised of the following tips:

- Ensure unit is installed in a well-ventilated, dust-free environment.
- Keep all liquids away from the device.
- Ensure environmental conditions meet factory specifications.
- Ensure unit is properly secured to a rack or shelf. Major shocks or jolts to the unit as a result of dropping it may cause damage to the sensitive electronics within the unit.
- Use the device in conjunction with an UPS if possible.
- Power down the unit before connecting and disconnecting accessories and peripherals.
- A factory recommended HDD should be used for this device.
- Improper use or replacement of the battery may result in hazard of explosion. Replace with the same or equivalent type only. Dispose of used batteries according to the instructions provided by the manufacturer.

Preventive and Cautionary Tips

To guarantee the card reader works properly, please read and obey the notes below.

- If the card reader is powered by the controller, the power supply distance is recommended to be no longer than 100m. If the distance is longer than 100m, you are advised to power the card reader by external 12V (range: -%10 ~ +%10) DC power supply, which is nonswitched and linear. To guarantee the communication between the controller and the card reader, you must use RVVP cable above 0.5 to connect them.
- If the card reader is installed outside or in environment easy to permeable, it is advisable to install a waterproof shield.
- If you need to install several card readers, the distance among them must over 30cm.
- To reduce the noise in long distance transmission, the shield of cable should connect to the GND of both controller and card reader terminal.

Content

CHAPTER 1 PREVENTIVE AND CAUTIONARY TIPS

CHAPTER 2 INTRODUCTION

2.1 FRONT VIEW

2.2 REAR VIEW

2.3 SIDE VIEW

CHAPTER 3 INSTALLATION

3.1 INTRODUCTION FOR DIPSWITCH

3.2 DEFINITION OF CABLE

3.3 WIRING CABLES

3.4 INSTALLING CARD READER

CHAPTER 4 SOUND PROMPT AND INDICATOR

Chapter 2. Introduction

VIS-3102 series card reader is a kind of high-performance product, with a 32 bit high-speed processor. It communicates with access controller via either RS-485 protocol or Wiegand protocol. And a build-in tamper-proof module helps to protect card reader from malicious damage. As to the physical appearance, the PC+ABS material makes water proof and dust proof possible in poor environment.

2.1 Front View

The front view of VIS-3102 series card reader is shown below:

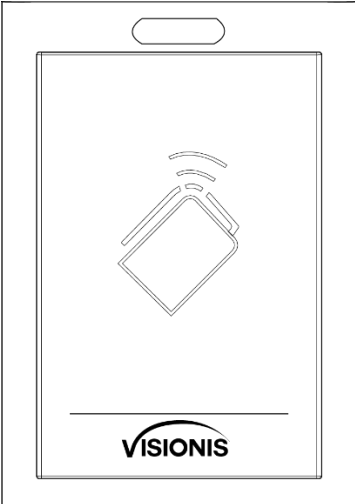

Figure 2-1 VIS-3102

2.2 Rear View

The rear view of card reader is shown below:

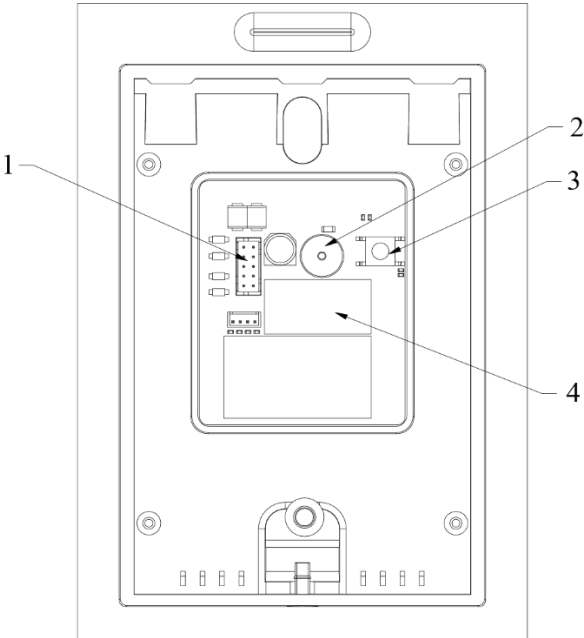

Figure 2-2 VIS-3102 Rear View

Table 2-1 Description of Rear View

No.	Name
1	Cable Interface of RS-485, Power, LED Control, etc.
2	Buzzer
3	Tamper-proof Module
4	DIP Switch

2.3 Side View

The side view of card reader is shown below:



Figure 2-3 VIS-3102 Side View

Chapter 3. Installation

3.1 Introduction for DIP Switch

The DIP switch module is shown below. The No. of DIP switch from left to right is 1 ~ 8.

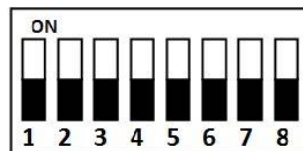



Figure 3-1 DIP Switch Module

Table 3-1 Description of DIP Switch

Icon	Description
	Represent 1 in binary mode
	Represent 0 in binary mode

For example, binary value of the following status is:00001100.

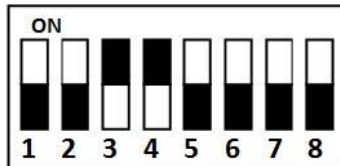

Figure 3-2 DIP Switch Module

Table 3-2 Description of DIP Switch

No.	Description	DIP Switch Status
1 ~ 4	Address of RS-485	1: 1 0: 0
6	Wiegand protocol or RS-485 protocol.	1: Wiegand protocol; 0: RS-485 protocol.
7	Wiegand Protocol (available when No. 6 is 1)	1: Wiegand protocol of 26-bit; 0: Wiegand protocol of 34-bit.
8	Matched Resistance (available for RS-485 protocol)	1: Enable; 0:Disable

3.2 Definition of Cable

The description of 10 cables is shown below.

Table 3-3 Description of Cable

Color	Description
Yellow	RS-485+
Brown	Blue LED Control (available for Wiegand Protocol)
Blue	RS-485-
Purple	Beep Control (available for Wiegand Protocol)
Gray	Case Sensor (available for Wiegand Protocol)
Green	Wiegand W0 (available for Wiegand Protocol)
White	Wiegand W1 (available for Wiegand Protocol)
Black	GND
Orange	Red LED Control (available for Wiegand Protocol)
Red	PWR (DC +12V)

3.3 Wiring Cables

Purpose:

Wire the cables between controller and card reader, thus to establish the communication between them.

Steps for RS-485 communication mode:

1. Set the DIP switch of No. 6 as 0.
2. Set the DIP switch of No. 1 ~5 for RS-485 address and reading card mode. For details, please refer to 3.2 *Introduction for DIP Switch*.
3. Wire the cable between controller and card reader as shown below.

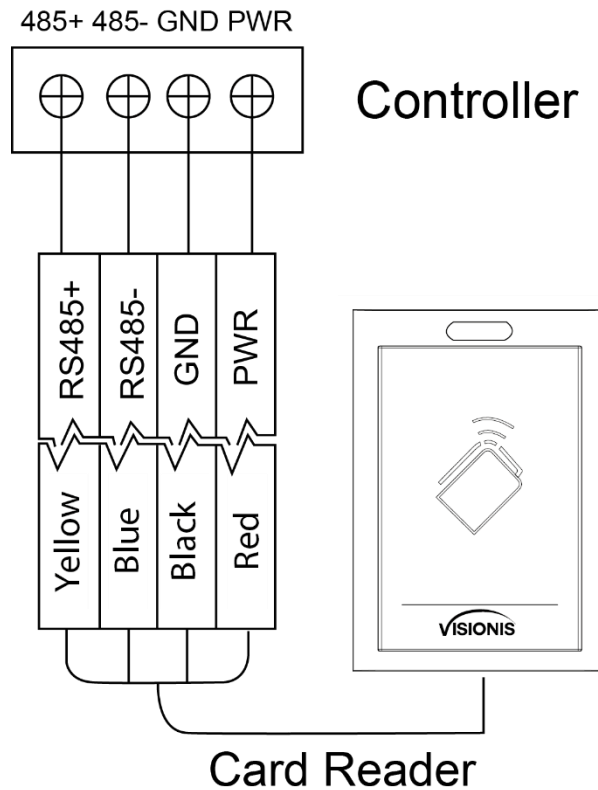

Figure 3-3 Wiring for RS-485 Communication Mode

Steps for Wiegand communication mode:

1. Set the DIP switch of No. 6 as 1.
2. Set the DIP switch of No. 5 and 7 for reading card mode and Wiegand protocol. For details, please refer to 3.2 *Introduction for DIP Switch*.
3. Wiring the cable between controller and card reader as shown below.

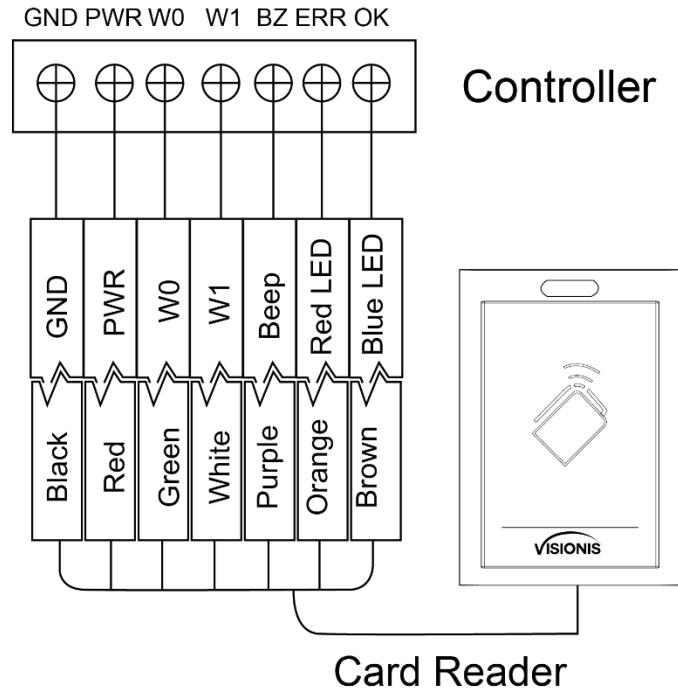

Figure 3-4 Wiring for RS-485 Communication Mode

3.4 Installing Card Reader

Before you start:

Set the DIP switch. For details, refer to 3.2 *Introduction for DIP Switch*.

Steps:

1. Fix the plate on the wall or other place.
2. Connect the cables between controller and card reader.
For details, refer to 3.4 *Wiring Cables*.
3. Push the card reader to match the fixed plate.
4. Fasten the screw to keep the components together.

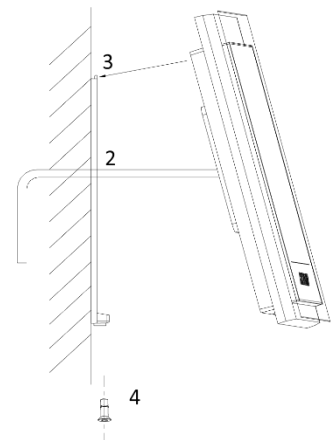
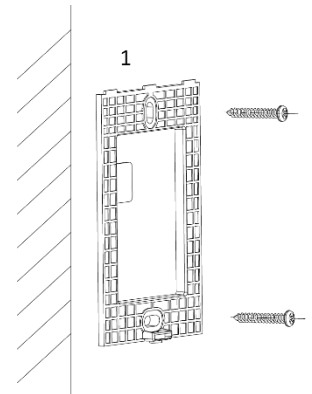

Chapter 4. Sound Prompt and Indicator

After the card reader is powered on, LED status indicator will turn blue and blink for 1time. Then it will turn red and blink for 3 times. At last the buzzer will send out a beep sound indicating the starting up process is completed.

During using the card reader, it will send out different sounds prompt and the LED indicator on it have different statuses. You can refer to tables below for detailed information.

Table 4-1 Description of Prompt Sound

Sound Prompt	Description
One beep	RS-485 protocol: Pressing keys prompt; Swiping card prompt; Time out prompt for pressing keys or swiping card. Wiegand protocol: Pressing keys prompt; Swiping card prompt.
Two rapid beeps	The operation of pressing keys or swiping card is valid.
Three slow beeps	The operation of pressing keys or swiping card is invalid.
Rapidly continuous beeps	Alarm of tamper-proof.
Slowly continuous beeps	The card reader is unencrypted.

Table 4-2 Description of LED Indicator

LED Indicator Status	Description
Blue and blinking	Card reader is working normally.
Solid blue	The operation of pressing keys or swiping card is valid.
Solid red	The operation of pressing keys or swiping card is invalid.
Red and blinking	For RS-485 protocol: Registering failed or card reader is offline.