



The VISIONIS series electromagnetic locks are renowned with its excellent holding force and the remarkable features.

The series compliance to UL, CE and PSB Test are manufactured under the highest quality control to achieve the commitment to customer who always satisfied with maximum quality and reliability.

Features

- Low Current Consumption
- Reliable Holding Force
- Hall Effect Sensor Monitoring Output
- Green/Red LED Indication for EM Lock Status
- Durable and Silence Operation
- Cosmeticize Anodized Aluminum Casing
- Surge & Spike Protection PCB
- Anti-Tamper Jam Nuts
- Full Range of Optional Brackets
- Anti Residual Magnetism Kick Off Button

Model No.	VIS-ML600LED-UL
Voltage Input	12 VDC / 24 VDC
Current Draw	12V / 500mA ; 24V / 250mA (±5%)
Holding Force	Up to 600 lbs (272 kg)
Hall Effect Contact	SPDT rated 2A at 24 VDC
Anti-Rust Surface Treatment	Blue Zinc Plating
Operating Temperature	0°C~55°C (32°F~131°F)
Operating Humidity	0~95% (non condensing)
Weight (Magnet)	1.1 kg (±1%)
Dimensions	Magnet = (L)250x(W)42x(T)25 mm - 9.84x1.65x0.98 in. Armature = (L)180x(W)38x(T)11 mm - 7.08x1.49x0.43 in.



Disclaimer: VISIONIS reserve the right to go ahead with any modifications of models or features or price without forewarning. All the information and specifications stated in this document are current at the time of publication. Attention: We are not responsible for the improper installation of this kit. If you are not handy with electrical equipment you should contact a professional electrician. You will also need to check with your local Fire authority to see if you need anything else to comply with local Fire Codes. We are not responsible for any damage or fees that can occur.



sales@visionistech.com



www.visionistech.com

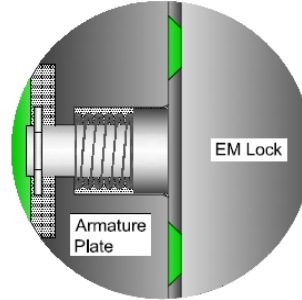
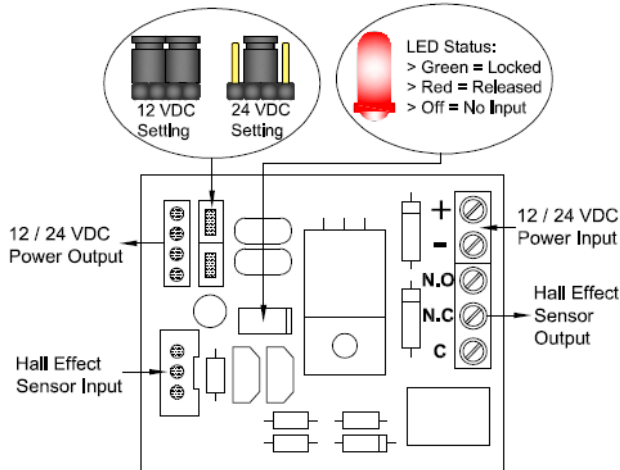

EM Lock Energized

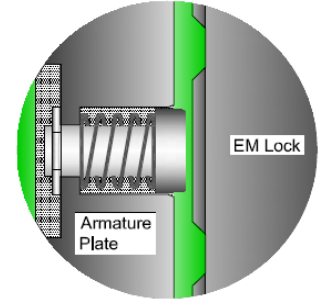

EM Lock De-energized

IMPORTANT!

Set the Jumper position according to the power input correctly before switch ON the power.



Disclaimer: VISIONIS reserve the right to go ahead with any modifications of models or features or price without forewarning. All the information and specifications stated in this document are current at the time of publication. Attention: We are not responsible for the improper installation of this kit. If you are not handy with electrical equipment you should contact a professional electrician. You will also need to check with your local Fire authority to see if you need anything else to comply with local Fire Codes. We are not responsible for any damage or fees that can occur.



sales@visionistech.com



www.visionistech.com