

DEIMOS BT

RANGE

Electromechanical automation for rack sliding gates up to 1,100Lbs and 75 Feet

DEIMOS BT UL/CSA

R925228 00002 - with 1 mitto transmitter

KR925228 00003 - with 1 mitto + Reflective Photo Eye

R925186 00002 - Deimos Only

SMART TECHNOLOGY

Electromechanical microswitches that control the end of stroke.

Incorporated two-channel rolling code radio receiver.

Self contained control panel unit with self-learning and self-diagnostic functions.

Control unit compatible with the EELink protocol and Solor compatible with "Ecosol" solar kit

SAFE USE

- This version powered at 24V has been specially designed for simpler and faster installation in compliance with latest safety standards.
- The 24 V electrical motor guarantees maximum accuracy in torque and speed control on the one hand, and on the other makes it suitable for intensive gate use, even in industrial installations. Optional battery back-up can be fitted within the operator casing. These operators are all "Ecosol" solar compatible.
- Thanks to the obstruction sensing device, the operator reverses motion and prevents damage to people and vehicles in the event of contact.



UL 325
COMPLIANT



TECHNICAL FEATURES

Control panel	QSC D UL (incorporated)
Reversible/irreversible operator	irreversible
Power supply	120 V 60 Hz single-phase
Absorbed power	0.1 hp (70 W)
Thermal protection	integrated in the control unit
Leaf speed	7.9 ips (12 m/min)
Output rotational speed	79 rpm
Pinion pitch	4 mm (14 teeth)
Impact reaction	electronic torque limiter
Limit switches	electromechanical
Manual release	mechanical release with knob
Operating cycle	intensive use
Environmental conditions	from 5°F (-15°C) to 122°F (+50°C)
Degree of protection	IP24
Operator weight	16 lbs (~7 kg)
Dimensions	see drawing next page



BFT Americas, Inc
6100 Broken Sound Parkway N.W.,
Suite 14
Boca Raton, FL, 33487

- T: US. 1877 995 8155
- info.bft@bft-usa.com
- www.bft-usa.com

tuned to you

DEIMOS BT

DIMENSIONS

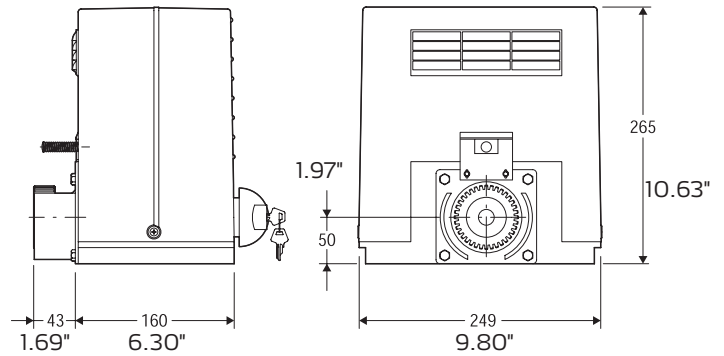

ACCESSORIES



PI25002 - SB BAT
24 Vdc battery backup system for DEIMOS BT, it includes a charger board that activates the batteries when power is off and charges the batteries when power is on.



P111376 - SCS 1
Serial connection interface for QSC D UL, RIGEL 5 and LEO D. 2 SCS 1 are needed for master & slave connection.



PI21024 - Q-BOX
Digital keypad with 10 channels and 100 combinations. Backlit



D571053 - CVZ
30x12 4mm pitch galvanised adjustable steel rack 3' 3" length.



D221073 - CP
22x22 4mm-pitch plastic rack with adjustment slots. 3' 3" length.



N190039 - CSP 10
Shock absorber profile, length 3' 3".



N190040 - CSP 20
Shock absorber profile, length 6' 6".



N190041 - CSP 25
Shock absorber profile, length 8' 2".



N999158 - MSC
Personalised key release knob.



D111904 Mitto 2 Transmitter:
12V Two channel 433Mhz rolling code remote control



D610180 - CLS/52
Release key for LUX, PHOBOS BT, PHOBOS BT L and DEIMOS BT .



D111754 00001 - QSCD
Replacement board for Deimos BT.



KED113731H - ECOSOL KIT
Includes Ecosol Interface, solar panel and 15' solar of panel cable, connection harness for easy installation, for running BFT control panels off 24V solar power. Includes two 12V 7.2Ah batteries and circuit board for management of commands to control panel and battery charge management, with built-in Rolling Code 433.92 MHz receiver with 63 stored positions.



BFT Americas, Inc.
6100 Broken Sound Parkway N.W.,
Suite 14
Boca Raton, FL, 33487

→ T: US. 1877 995 8155
→ info.bft@bft-usa.com
→ www.bft-usa.com

tuned to you