

ARES

RANGE

Electromechanical automation for rack sliding gates up to 75'

ARES 1000/1500

P926183 00001 - ARES 1000 - Gates up to 2,200 LBS

P926183 00005 - ARES 1000 FAST - Gates up to 1,100 LBS

P926182 00001 - ARES 1500 - Gates up to 3,300 LBS

P926182 00005 - ARES 1500 FAST - Gates up to 1,650 LBS



Now even wider:

- ARES 1000 and ARES 1500 operators widen the BFT range of sliding gate operators. Rated with the "medium-heavy" weight range, they integrate with existing products to obtain an operator that is perfectly suited to the gate every time.

Low voltage motor:

- The 24 V electrical motor guarantees maximum accuracy in torque and speed control on the one hand, and on the other makes it suitable for intensive gate use, even in industrial installations. Optional battery back-up can be fitted within the operator casing. These operators are all "Ecosol" solar compatible



TECHNICAL FEATURES

	ARES 1000 / 1000 Fast	ARES 1500 / 1500 Fast
Control panels	HQSC-D (incorporated)	HQSC-D (incorporated)
Reversible/irreversible operator	irreversible	irreversible
Power supply	120 V 60 Hz single-phase	120 V 60 Hz single-phase
Absorbed power	240W	400W
Thermal protection	integrated	integrated
Leaf Speed	5.9 ips (9m/min) / 7.9ips. Fast	5.9 ips (9m/min) / 7.9ips. Fast
Pinion Pitch	4 mm (18 teeth) / (25 Teeth Fast)	4 mm (18 teeth) / (25 Teeth Fast)
Impact reaction	electronic torque limiter	electronic torque limiter
Manual release	release knob	release knob
Operating cycle	intensive use	intensive use
Environmental conditions	5°F (-15°C) to 140°F (60°C)	5°F (-15°C) to 140°F (60°C)
Degree of protection	IP24	IP24
Operator weight	44 lbs (~26 kg)	44 lbs (~26 kg)
Leaf weight	up to 2,220 lbs (~1000 kg) Fast Model 1,110 lbs (~500 kg)	up to 3,300 lbs (~1500 kg) Fast Model 1,650 lbs (~825 kg)



BFT Americas, Inc.
6100 Broken Sound Parkway N.W.,
Suite 14
Boca Raton, FL, 33487

tuned to you

- T: US. 1877 995 8155
- info.bft@bft-usa.com
- www.bft-usa.com

ARES

DIMENSIONS

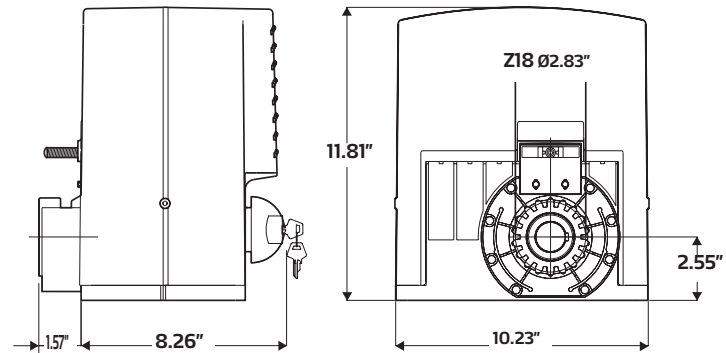

ACCESSORIES



P125009 - BT-BAT 2
24 Vdc battery backup system for ARES, it includes a charger board that activates the batteries when power is off and charges the batteries when power is on.

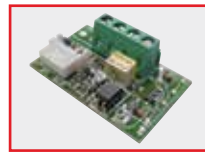

P111376 - SCS 1
Serial connection interface for QSC D, H-QSC D RIGEL 5 and LEO B CBB. 2 SCS 1 are needed for master & slave connection.



D221073- CP
22x22 4mm-pitch plastic rack with adjustment slots. 3' 3" length.



D571053 - CVZ
30x12 4mm pitch galvanised adjustable steel rack 3' 3" length.



D730298 - 25 TEETH PINION
Larger pinion for increased speed (7.9ips, 12rpm). Max gate weight Ares 1000 1100lb (500Kg) & Ares 1500 1650lb (750Kg).



D531548 - KI
Blank spare key for release knob



D111862 00001 - H-QSCD 120V
Replacement board for ARES 1000 and 1500.



D111904 Mitto 2 Transmitter:
12V Two channel 433Mhz rolling code remote control



P121024 - Q-BOX
Digital keypad with 10 channels and 100 combinations. Backlit



KED113731H - ECOSOL KIT
Includes Ecosol Interface, solar panel and 15' solar of panel cable, connection harness for easy installation, for running BFT control panels off 24V solar power. Includes two 12V 7.2Ah batteries and circuit board for management of commands to control panel and battery charge management, with built-in Rolling Code 433.92 MHz receiver with 63 stored positions.



BFT Americas, Inc.
6100 Broken Sound Parkway N.W.,
Suite 14
Boca Raton, FL, 33487

tuned to you

→ T: US. 1877 995 8155
→ info.bft@bft-usa.com
→ www.bft-usa.com